

# CDI

## FLEXIBLE FURLER 2

### INSTALLATION / OPERATING INSTRUCTIONS



277 Baker Ave, PO Box 1250, Concord MA 01742  
Tel. 978 371 5508 Fax. 978 371 5597  
Website: [www.sailcdi.com](http://www.sailcdi.com)

Updated April 2003

## **WARNINGS – READ BEFORE INSTALLING OR USING YOUR FURLER**

Improper installation of the Flexible Furler or improper reinstallation of the forestay can cause failure of the forestay, and could result in the loss of the mast and injury to crew members.

### **PRE-INSTALLATION WARNING:**

You must use **toggles at both ends of the forestay**. Improper toggling may cause the forestay to fatigue due to bending stresses.

### **POST INSTALLATION WARNINGS & SAFETY CHECKLIST:**

1. All **clevis pins** and **cotter pins** (especially **turnbuckle cotter pins**) removed during installation must be replaced.
2. **Turnbuckle threads** must have full engagement.
3. Make sure your furler **rotates freely**.
4. The luff and the inside of the drum **must not touch the turnbuckle body**. If they touch, furling may unscrew the turnbuckle.
5. The **luff support pin** must be installed, or the turnbuckle will unscrew and cause dismasting.
6. Insure that the **bearing is not jammed**, as winching with a jammed bearing will transmit torsional loads to the turnbuckle which could lead to failure.
7. There must be at least **3” clearance** on the sides and above the halyard top fitting.

### **OPERATION WARNINGS & SAFETY CHECKLIST:**

1. **Never winch** the unit without checking for jams or snarls. Winching against an obstruction can sever or cause hidden damage to your forestay.
2. Keep your unused halyards **flipped to the after side** of your spreaders and **lightly tensioned**.
3. If the unit becomes hard to furl, **investigate and correct the cause**. Failure to do so can lead to the failure of the forestay.

### **USAGE WARNINGS:**

The Flexible Furler is NOT designed to be used while your boat is in the water and passing under low clearance obstructions (bridges, power lines, etc.) with mast tipped forward and headstay attached to the bow. Lowering the mast in this manner is dangerous even without a furler, and can be further complicated by the weight of the furler and the sail.

“This product is intended for use only on sailboats having masts fixed vertically in place at all times while the boat is in the water, wherein the mast may only be lowered in accordance with the boat manufacturer’s instructions when the boat is on land. **Any other use of the product constitutes misuse, and may result in damage to the product, and/or serious injury to the user.**”

## INDEX

Warnings & Safety Checklists.....	Inside Front Cover
Specifications.....	1
Drawing.....	2
Parts List.....	3
Uncoiling and Straightening the Luff.....	4 – 5
Assembly.....	5 - 9
Installing the Furling Line.....	10 - 11
Hoisting the Jib.....	11 - 12
Lowering the Jib.....	12
Sailing with your Furler.....	12 - 13
Trailing Instructions.....	13 - 14
Maintenance & Storage.....	14
Sailmaker's / Rigger's Instructions.....	15
Warranty.....	Back Cover

## SPECIFICATIONS

Headstay Length 29 feet, maximum

Wire Size 1/8", 5/32", 3/16"

Headstay Fittings There must be a toggle at both ends of the headstay. The turnbuckle must be a 1/4" or 5/16" swage on turnbuckle with a T-bolt and toggle on the bottom (see page 5). *It MUST be locked by cotter pins.* You may NOT use 3-piece (Navtec) turnbuckles. The stud must NOT have non-marine protuberances (such as aircraft hex nuts). If your turnbuckle doesn't meet *all* of the above requirements, replace it with one that does.

Mounting The system can NOT be mounted above the turnbuckle. If you wish to raise the system for better clearance, shorten the stay and use link plates below the turnbuckle.

Furling Line 5/32" or 3/16" braid on braid dacron. If you prefer a larger diameter, you should de-core the portion of line forward in the cockpit. (Otherwise the larger line won't fit onto the furling drum.)

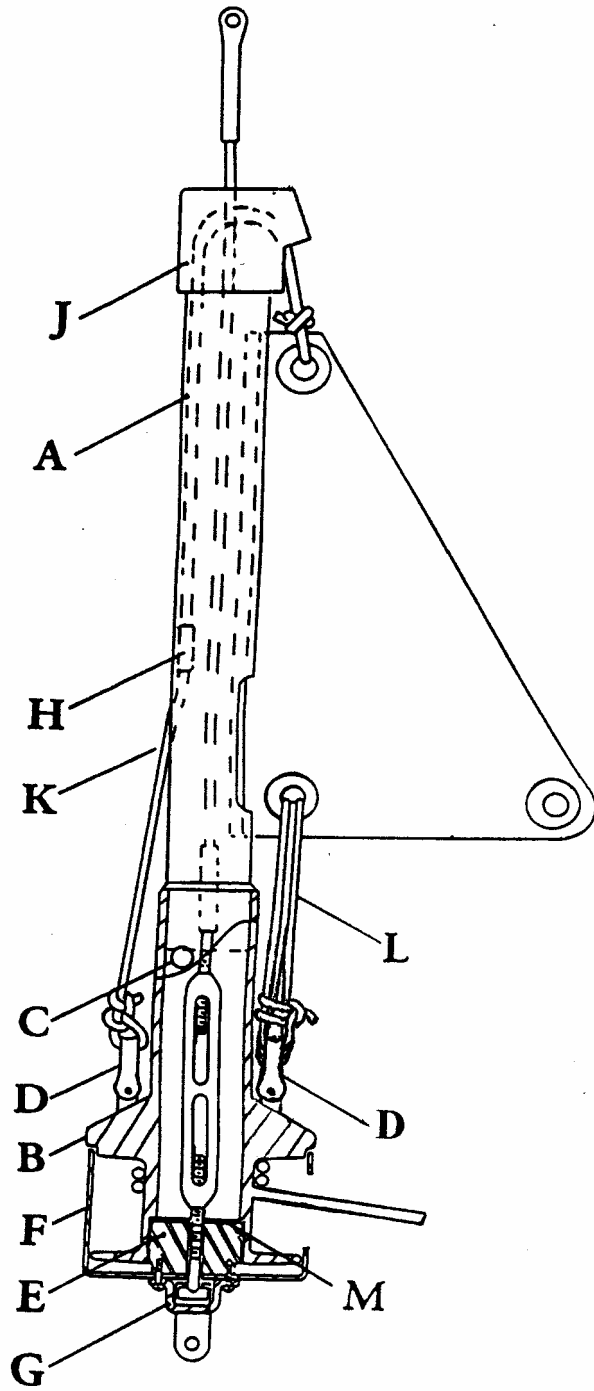

(2)

## PARTS LIST

<u>Ref</u>	<u>Description</u>	<u>Part#</u>
A	Luff	LFF2
B	Furling Drum Assembly	2010
C	Luff Support Pin (3/16" x 2 1/32")	2009
D	Anchor Pins	1998
	Shackle	2007
E	Main Bearing, HDPE plastic (standard)	1033
	or	
	Ball Bearing, torlon balls (optional)	BB2
F	Cup, stainless steel	1807
G	Antirootation Strap	1081
H	Ferrule (the little metal tube swaged on halyard)	- -
J	Halyard Top Fitting	2011
K	Halyard Assembly, 1/4" x 33'	1932
L	Tack Tension Line, 1/8" x 4'	2048
M	Thrust Washer	1253
	Instruction Manual (not shown)	1049

## **UNCOILING AND STRAIGHTENING THE LUFF – PLEASE READ CAREFULLY!**

If you received the luff coiled, BE CAREFUL when cutting the tape that holds the luff in the coil. THE LUFF CAN UNCOIL WITH CONSIDERABLE FORCE AND CAUSE INJURY. If you are hesitant about straightening the luff, don't cut the tape. Once the coil is cut, you can't return it for credit. If you haven't cut the tape, you can return the luff for a full credit, and have us ship you another one in a 6' hoop. If you uncoil the 6' hoop within a few days of receipt, it requires no straightening.

It is easier to straighten the coil in warm weather (72 degrees F or higher). If it's cold outside, first allow the coil to warm up inside. Then take it out to uncoil (see below). Bring it back inside to accelerate straightening.

Start removing the tape by cutting the band retaining the outside end of the coil while restraining the outer wrap. Gently uncoil to the next band of tape. Repeat this process until all tape has been removed. When cutting the last piece, the coil will have a tendency to spring outwards, so be cautious. Never cut the tape restraining the inner end first as the coil will spring open when the last tape is cut.

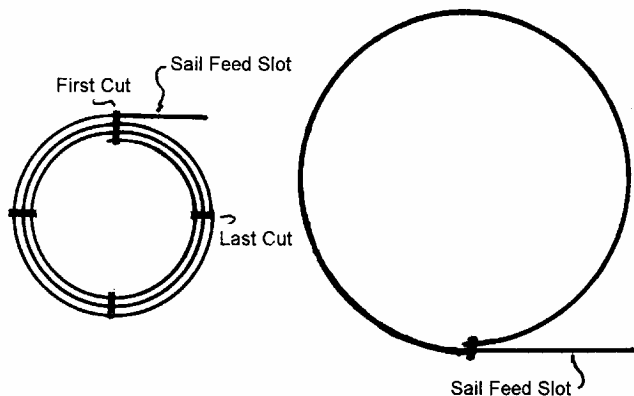

When the tape is removed, the luff will still have a coiled shape. To straighten, find at least two additional people (preferably more) and recoil the curved portion in one large loop in the opposite direction. Keep the luff level to prevent twisting. Note that the lower end, from the sail feed slot to the bottom, was shipped straight and should not be recoiled (see drawings above).

After coiling in the opposite direction, tape the upper end to the lower portion above the sail feed slot, leaving the straight portion free. Let the coil stand for several hours: a minimum of three if it's warm, longer, perhaps overnight, if it's cold. After this time, carefully cut the tape and check the straightness. The luff does not need to be perfectly straight as a tight forestay will finish the job.

**Removing Kinks:** If your luff has been stored improperly, coiled or bent for a long time, the best technique is to place the entire luff inside a pipe, tube or mast and let it sit outside in direct sunlight for 1-2 weeks in the summer. NEVER try to straighten the luff by using a hair dryer or by laying it on the ground and weighting it down along its length. These techniques don't work and void the warranty.

## ASSEMBLY

Assembly is easiest with the mast down, although assembly can be done with the mast up.

1. Measure the pin-to-pin length (L below) of the forestay with the turnbuckle in its normal state of adjustment. If the mast is up, you will have to raise a tape on the jib halyard and add an amount approximately equal to the distance from the top end of the tape to the pin at the top of the forestay. Cut the top end of the luff so that the total luff length is 12.25" less than the pin-to-pin length.

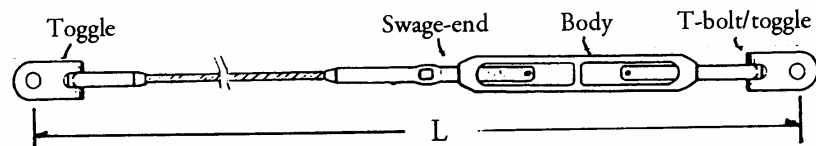

2. The Flexible Furler uses an internal halyard instead of your ship's halyard. Notice that ONE end of the halyard is de-cored and has a small metal ferrule swaged onto it. Push the OTHER end of the halyard up into the cavity in the halyard top fitting and through the off-center hole until the halyard exits out the side (see photos next page). Pull the rest of the halyard through the halyard top fitting until the ferrule is near the bottom of the halyard top fitting.

Note: Occasionally you may need a pre-feeder to get the halyard to feed easily into the halyard top fitting. If so, use a cigarette lighter and melt a piece of 1/8" line to the "OTHER" end of the halyard (see instruction #2 on previous page).



Feed halyard into HTF & out the side. (bottom view)



Pull halyard thru HTF. Ferrule gets inserted into the top of the luff extrusion.

3. Pass the decored line through the groove in the top of the luff extrusion that is opposite the sail feed slot (see photo below) and slide the ferrule down inside the groove.

Ferrule



sail feed slot

Starting the ferrule down the luff extrusion

4. Push the halyard top fitting over the top of the luff and secure with the locking screw. Make sure the "OTHER" end of the halyard (the end without the ferrule) exits the halyard top fitting on the same side as the sail feed slot, and slides freely. (See diagram on page 2.)
5. Tie a light line, the length of the luff, to the decored end. This messenger line will be used to raise the sail.
6. Completely unscrew both ends of the turnbuckle.

7. Pass the forestay, starting with the swage-end, down through the halyard top fitting /luff assembly. If the mast is up, pass a light line through the luff and make it fast to the cotter pin hole in the swage-end of the turnbuckle using a piece of wire to make the link. Pull the line while pushing the luff up the forestay. When the swage-end and wire appear, screw on the turnbuckle body to prevent the luff from falling down.



connecting swage stud to messenger line



pushing extrusion up forestay



screwing turnbuckle on stud

8. If the turnbuckle thread size is 5/16" in diameter, drill out the center hole of the bearing with a 21/64" drill.
9. Place a washer over the T-bolt. Add extra washers on top of the T-bolt to increase the reach of the clevis pin to the chain plate hole (see photos below).
10. Select the appropriate pair of holes (on the bottom of the cup) based on the orientation of the chainplate and furling line. (See page 10 for more information.) Then screw the antirotation strap, bearing and cup together.



Adding washers to the T-bolt so the toggle will reach the chain plate hole



Assembling cup, bearing and antirotation strap

(7)

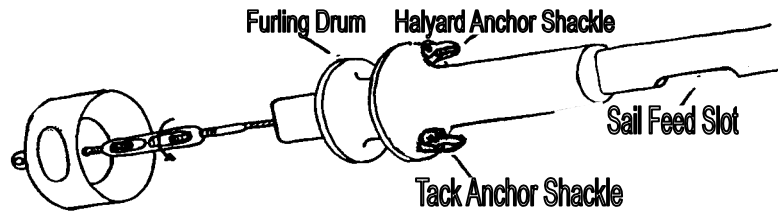

11. Slide the furling drum over the luff with the sail feed slot on the same side as the tack anchor shackle (see drawing above). You may knock the thrust washer (part "M" on page 2) out of place doing this. You can push the washer up into the cavity of the furling drum again. The washer is designed to ride between the furling drum and the bearing.

12. Screw the T-Bolt into the turnbuckle body and adjust until the overall length is correct. BE SURE TO REPLACE THE COTTER PINS IN YOUR TURNBUCKLE. Also, remember to INSTALL THE LUFF SUPPORT PIN when you lower the furling drum.



13. Pass the furling line through the hole in the side of the cup, then up through the hole in the top of the furling drum flange. Tie an overhand knot to prevent it from escaping.



14. Step the mast (if unstepped). Attach the forestay to the chainplate. Tension rig using backstay turnbuckle or upper

shrouds (if there is no backstay). If the forestay needs to be adjusted, remove the luff support pin and slide up the furling drum to expose turnbuckle.

15. Slide the furling drum down the luff, into the cup and over the main bearing. Lift the luff off the turnbuckle body. Insert the luff support pin through the hole in the furling drum throat. The luff rests on top of this pin (see picture). No hole in the luff is needed for the pin. CAUTION: the luff must not sit on the turnbuckle body as turning the furler might unscrew the turnbuckle causing dismasting.



Furler w/ luff support pin installed

16. If your jib is full or almost full hoist, pull the halyard ferrule hard up against the halyard top fitting and cut the halyard so that when it is tied to the sail, the head of the sail is just below the sail feed slot. Melt end of rope to prevent fraying.

If your sail is not a full hoist sail, estimate the distance from the head of the sail to the mast when the sail is raised. Call this estimated distance "dimension A." With the halyard ferrule hard up against the halyard top fitting, cut the halyard so that the head to the sail is below the sail feed slot by an amount approximately equal to "dimension A." When the sail is raised, there must be enough decoed halyard to reach and be made fast to the halyard anchor shackle. This may take some experimentation so cut the halyard only after you confirm the length.

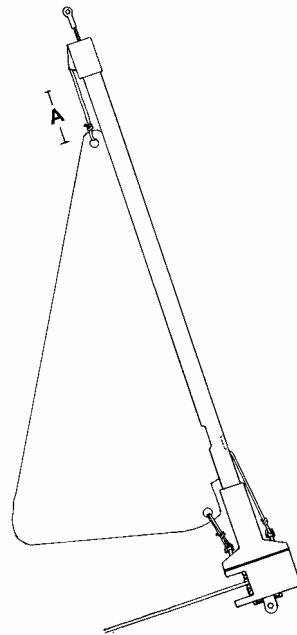

Note: When the sail is UP, the ferrule (little metal tube swaged on halyard) is DOWN near the spool.

## INSTALLING THE FURLING LINE (*Please Read Carefully*)

1. Pass the furling line through the opening in the side of the cup, then up through the hole in the top of the furling drum flange. Tie an overhand knot to prevent it from escaping. Before raising the jib, rotate the furler so there are about 20 turns of furling line on the furling drum.
2. Position the first fairlead or block so that the furling line exits the cup at right angles to the forestay and approximately in the middle of the cup athwartships. Failure to properly position this first lead can result in chafing and cutting of the furling line. In most cases, the first fairlead must be mounted on the deck. Properly bed the screws. If using a sunscreen on your sail, the furling line should be wrapped so the sunscreen is on the outside of the sail when the sail is furled. (The furler can work rotating in either direction.)

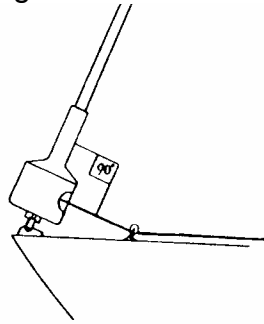

Locating the first Fairlead

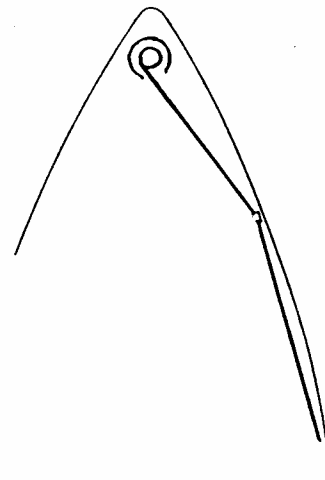

Possible deck layout if UV is on starboard side

3. If you wish to position the first lead at the rail, you may have to turn the cup 45 degrees to the centerline. This may be done by selecting a different pair of holes when installing the antirotation strap.
4. Place a cleat near the cockpit and away from other sail handling equipment. When the sail is furled, there's a lot of line to stow.

5. Place a cleat in a convenient place out of the way of other sail handling equipment. When furled, you will have a lot of line that needs to be kept clear of other gear.
6. The system is designed for 5/32" or 3/16" dacron line. Make sure you have enough to completely furl your largest sail plus about five extra turns. This will allow you to furl an extra tight furl in heavy winds and still have a couple of turns left. Before hoisting the sail for the first time, wind about twenty turns on the spool. Turns can be added or subtracted as necessary after setting the sail.

## HOISTING THE JIB

1. Attach the halyard to head of the jib.

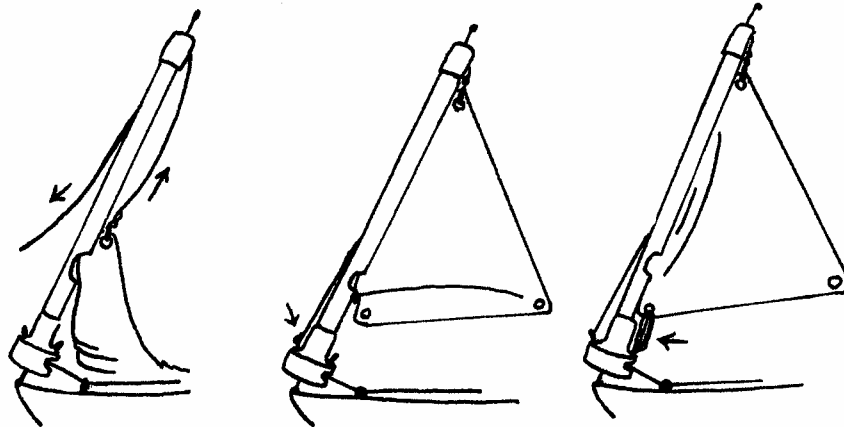

Pull decored end of halyard down to hoist sail.

Tie decored end of halyard to halyard shackle

Tension at the bottom of the sail using tack tension line. Lace it 3 or 4 times.

2. Pull up the sail by pulling down on the messenger line attached to the decored end of the halyard while feeding the luff tape into the sail feed slot. If raising and lowering the sail frequently, a pre-feeder should be added.
3. When the sail is fully hoisted, remove the messenger line and make the end of the decored end fast to the halyard anchor pin and shackle.
4. Tension the luff of the sail with the 1/8" tack tension line, passing two or three parts through the downhaul shackle on furling drum flange and grommet on sail, and finish off with some half hitches.

5. Add or eliminate furling line on drum as necessary. When sail is furled tightly, there should be 5 to 10 turns left on the furling drums.

## LOWERING THE JIB

1. Cast off the halyard tension line. Tie a messenger line to the decored end of the halyard.
2. Lower the jib.

## SAILING WITH YOUR FURLER

**Luff Tension.** The jib requires only enough tension to remove the wrinkles along the luff of the sail. This tension will be quite low (perhaps 50 pounds) because modern sails are quite stiff, requiring little stretching, and because the luff tape will prevent scalloping often encountered with hank-on sails. This allows the sail to be set up for the entire season without need for adjustment before and after each use.

**Foam Tape / Shape Tape.** Because modern sails are quite stiff, the draft can be controlled with small changes in luff tension. If you are sailing to windward frequently in heavy weather and reef a lot, it may be appropriate to have a foam shape tape installed on the luff which will help remove the belly in a reefed sail. We suggest you consult your sailmaker.

**Furling & Reefing.** When sailing reefed, you must move the jib leads forward to maintain the power sheet angle. Failure to do so will lead to poor sail shape and could also cause the furler to rise off the bearing.

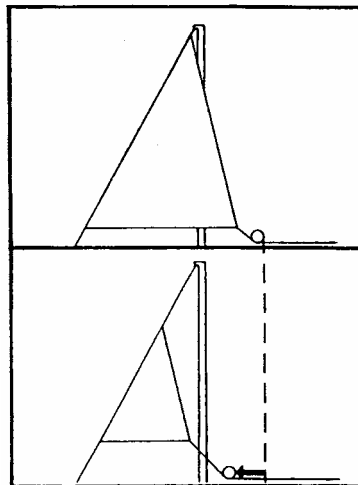

Sheet Lead Change

If after adjusting the lead block forward you still experience the furler lifting up off the bearing, add a piece of PVC tubing over the stay between the halyard top fitting and mast. This will prevent the system from rising up too much. Leave about  $\frac{1}{4}$ " play between the halyard top fitting and tubing.

To furl or reef, ease the sheet and pull the furling line until you reach the amount of sail you wish left deployed. Cleat down the furling line. Note: Letting the sheet go all the way may make furling a little easier but will result in an uneven furl.

To unfurl or unreef, ease the furling line while trimming the sheet. Always keep some tension on the furling line to insure a smooth wrapping of the furling line on the drum.

In certain conditions, you may wish to use a winch to get the furling started. Be careful that there is no extraneous ship's halyard wrapped in the furler while you winch as this could eventually jam the furler and/or damage the headstay. Always look up at the top of the furler while winching, and stop to clear any snarls. Furling should not get any more difficult as the sail is brought in. It should get easier. If it gets harder, stop and determine why.

Always keep unused halyards flipped aft of the spreaders and lightly tensioned. Do not clip them to the bow.

## **TRAILERING WITH YOUR FLEXIBLE FURLER**

Your Flexible Furler is designed to take a lot of abuse. However, if you plan to trail your boat, there are some precautions that will help avoid problems not normally experienced while sailing.

If you leave the furler lashed along the mast while trailering, do not let the furler sag in the middle or at the ends. Pay particular attention to the bottom end as it will probably overlap the bottom of the mast and tend to bounce. To support the drum/cup assembly, lash an extension to the bottom of the mast and tie the bottom of the furler to the extension. Do not bend the furler on itself to prevent whipping.

Never lash or store the furler in such a way as to cause a sharp bend. The luff will "remember" the bend. If this inadvertently happens, it is not covered under the warranty, but can be straightened by bending the luff in the opposite sense until it comes straight. Another option is to put the luff in a pipe or tube outside in the sun for one to two weeks to straighten it.

## MAINTENANCE & STORAGE

The Flexible Furler is a set-it-and-forget-it furling and reefing system. No routine maintenance is required, but an occasional rinsing with fresh water is a good idea. We do not recommend the use of wet lubricants (grease) as such lubricants can trap wear causing dirt particles in the bearing area. Dry lubricants (teflon sprays, etc) are fine to make furling easier.

When storing for prolonged periods, it is best to strap the furler along the mast, supporting the furler to avoid any potential sagging at the ends as well as in the middle. Do not allow it to drape over the spreaders or any other fitting as the plastic will creep and the luff will kink. Luffs must be stored flat and straight, or warranty is void.

Do not expose the furler to temperatures above 140 degrees F. Such temperatures may frequently occur in warm climates under a boat cover. The higher the temperature, the faster a bend becomes permanent.

To clean the luff, use a rag soaked in paint thinner. For deep scratches and ground in dirt, rub with a rag soaked in acetone. Acetone actually dissolves the luff so even deep scratches can be removed.

## BALL BEARING MAINTENANCE (IF INSTALLED)

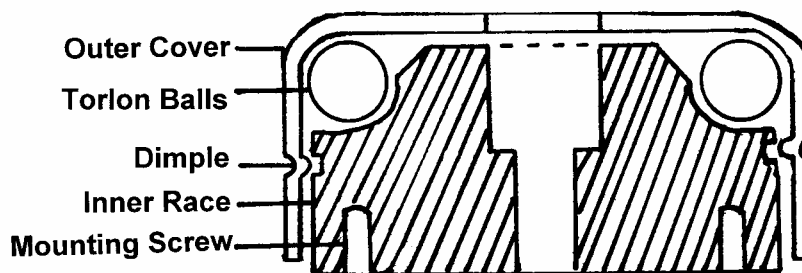

The ball bearing should be rinsed occasionally with fresh water. If the bearing is hard to turn, disassemble for a more thorough cleaning. To do so:

1. Remove the bearing assembly from the headstay.

2. Hold the bearing over a box so that when the balls fall out, which they inevitably will, they won't roll into oblivion.
3. Note that there are two dimples on the outer cover. Grasp the outer cover with your thumb and a finger each at 90 degrees from the dimples. Squeeze. The dimples will clear the inner groove, the cover will slide off, and the balls will fall out.
4. Clean all the balls and the race. Fresh water is normally sufficient, although grease must also be removed if present.
5. Reassemble the bearing, cup and antirotation strap.

## **SAILMAKER'S & RIGGER'S INSTRUCTIONS**

Luff tape required is #6. Sail luff deduction is 13" from pin-to-pin length.

We recommend use of webbing at the head and tack instead of metal grommets. This allows the sail to reef and furl more evenly.

The Flexible Furler can not be mounted above the turnbuckle as it might put excessive torsional stress on the turnbuckle that could lead to the unscrewing of the turnbuckle and dismasting. To raise the system, shorten the headstay the desired amount and install link plates under the turnbuckle.

The FF2 can be used with ¼" and 5/16" turnbuckles. The turnbuckle must have a threaded swage-end and T-bolt toggle. Stays with other fittings (eyes, jaws, etc.) must be altered, as the antirotation strap will not fit using these other fittings. *You must replace closed body, locknut turnbuckles with open body, cotter pinned turnbuckles.* Lock nuts are not a satisfactory way to lock turnbuckles. Any improper installation could lead to an unscrewing torque on the turnbuckle lock nuts, allowing the turnbuckle to unscrew and the mast to fall down. This can lead to injury or death.

Toggles are required at the top of the headstay as well as the bottom.

## **LIMITED 6 YEAR WARRANTY**

The Flexible Furler is warranted to remain functional for 6 years from date of purchase. You must be the original purchaser of the unit. If, during this period, any part becomes non-functional, CDI will repair or replace it, free of charge, except for the freight.

This warranty covers:

At Sea: winching against obstructions, unseamanlike use, and dismastings.

In Boatyards: rough and abusive handling while hauling or launching boats. The luff is warranted even if run over by light vehicles, excluding 3/4 ton or larger pick-up trucks, marine railways and travelifts.

On Trailers: raising and lowering the mast in accordance with boat manufacturer's instructions when the boat is on land.

Other: This warranty remains in force for charter and other commercial operations. No maintenance is required to keep the warranty in force.

The Flexible Furler warranty does not cover:

At Sea: Shipwreck, collision and acts of God. The warranty is void if the mast is not fixed in place vertically at all times while the boat is in the water. Tipping the mast forward to pass under bridges, power lines or other low clearance obstructions voids the warranty.

On Trailers: Collision; being dragged on the ground; improper stowage resulting in kinks, bends and twists; and damage due to the luff not being supported over its entire length. (See trailering instructions.)

Storage: Luffs must be stored flat and straight, or warranty is void. Kinks, twists, bends and breakage due the luff not being stored flat and straight are not covered. Coiling or twisting the luff either to remove kinks and bends, or for transport and storage in other than in a flat and straight condition voids the warranty.